

310 RID & RIDH WB10 Breeze*

*Dimensions only. Capacity ratings do not apply to WB10 Breeze.

SPECIFICATIONS, MAXIMUM CAPACITIES & LIFTING POINTS



WALKER BAY

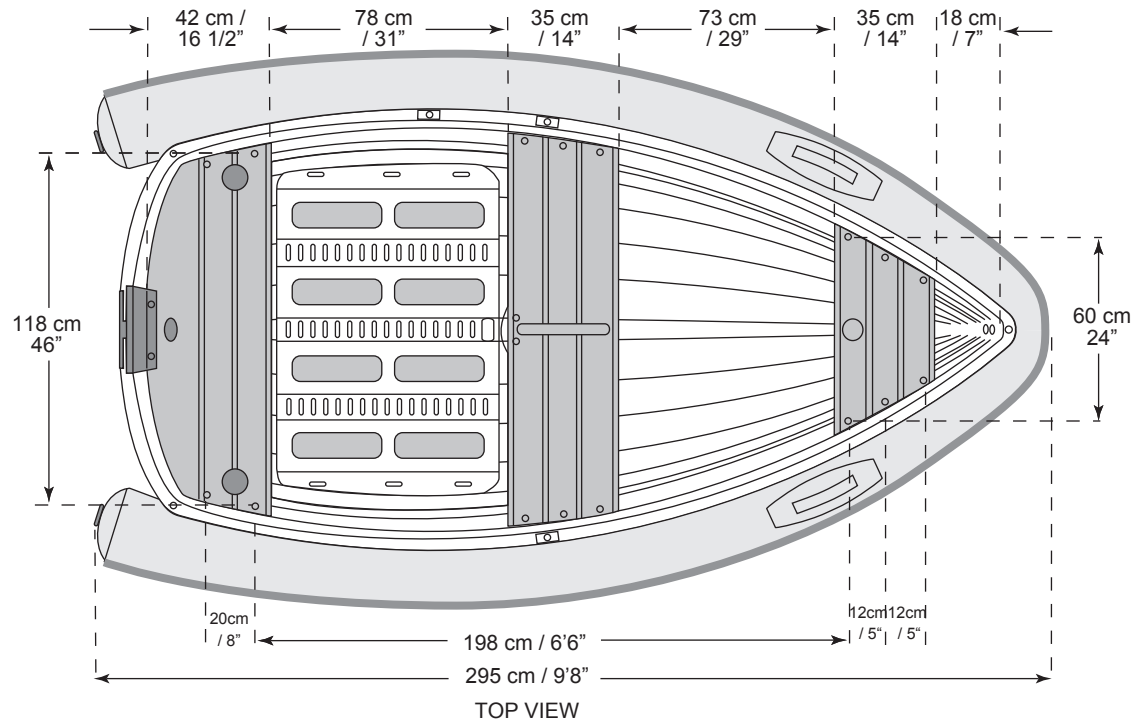
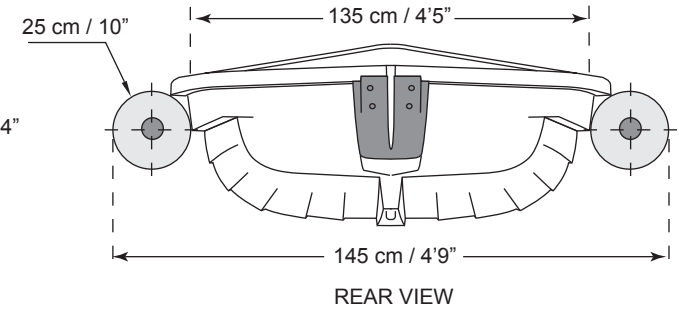
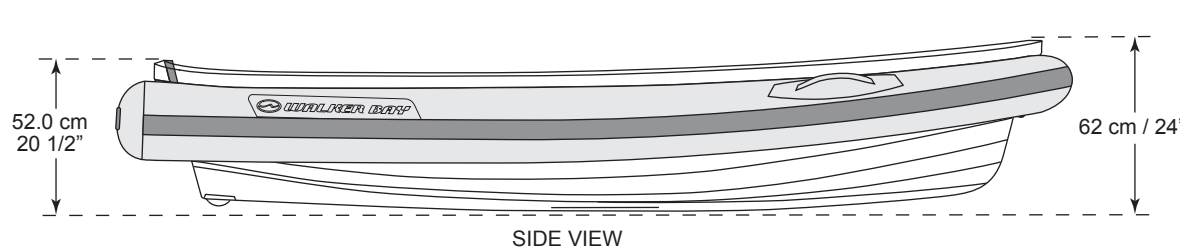

LIFTING POINTS

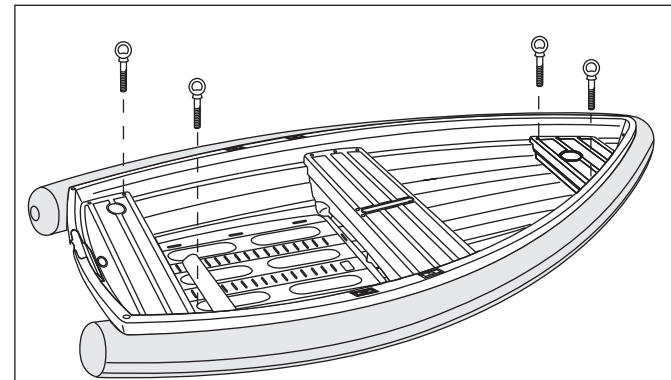

- Lifting eyes can be added quickly and easily to your Walker Bay 10 w. RID 310.
- Simply replace 4 of the 1/4" #20 bolts securing the front and rear seats with 1-1/2" x 1/4" #20 stainless steel eye bolts (Eye bolts not included with boat).
- Make sure eye bolts are securely fastened.
- Check lifting eyes periodically to make sure they are securely fastened.

SPECIFICATIONS

MAXIMUM CAPACITIES

Tolerances +/- 3%

DESIGN CATEGORY (CE):	D
WEIGHT:	68 kg / 149 lb
OVERALL LENGTH (LOA):	310 cm / 10'2"
BEAM:	183 cm / 6'0"
INSIDE BEAM:	135 cm / 4'5"
DEPTH:	62 cm / 2'
MOTOR SHAFT LENGTH:	Short (15")
DISPLACEMENT:	1239 kg / 2726 lb

USA / USCG*	
MAX LOAD:	572 lb
MAX PERSONS:	4
MAX PERSONS WEIGHT:	477 lb
MAX ENGINE POWER:	6 hp
MAX SPEED** (KNOTS/MPH)	6-8kt / 7-9mph
MAX SAIL AREA:	70 ft ²

EUROPE / CE / ISO*	
MAX LOAD:	372 kg
MAX PERSONS:	4
MAX PERSONS WEIGHT:	300 kg
FULLY LOADED CAFT WEIGHT:	440 kg
MAX ENGINE POWER:	4.5 kw
MAX SPEED** (KNOTS/KPH)	6-8kt / 11-15kph
MAX SAIL AREA:	7 m ²

*Capacity rating formulas are different for Europe and the United States; therefore, Maximum Load, Maximum Persons Weight and Maximum HP are different.

**Maximum speeds are estimates. Actual top speed will vary depending on type, make and model of motor and load in boat. The Walker Bay 8 and 10 hulls are displacement hulls, not planing hulls.